



der Rückspiegel

February 2023



2023 Mercedes-Benz EQE 350 4Matic®
An evolution of electric luxury.



Vin Devers Autohaus

5570 Monroe Street • Sylvania, Ohio • 419-885-5111 • www.vindevers.com



► Loaners ► DealerRater ► Free Pickup & Delivery

2023 Audi Q5 45 S line Quattro Premium Plus
The SUV Benchmark



Audi
Magna Society
Audi Sylvania
5570 Monroe St. | Sylvania, OH
www.sylvaniaaudi.com

We invite you for a test drive today.

FINANCIAL EXPERTISE, RIGHT AROUND THE CORNER
FOR YOUR COMMERCIAL AND PERSONAL NEEDS

Waterford®
BANK, N.A.

Equal Housing Lender, Member FDIC

Redefining Relationship Banking

3900 N McCord Rd. Toledo, OH 43617 | Phone: 419-720-3900 | Toll-Free: 866-707-2871
231 Louisiana Ave. Perrysburg, OH 43551 | Phone: 419-931-8750 | Toll-Free: 855-896-2066

www.waterfordbankna.com | NMLS# 520256

CLEAR AUTO BRA
MICHIGAN
PROTECT YOUR PAINT



558 FARMER • PLYMOUTH, MI 48170
ph: 734.259.0021 • larry@ClearAutoBraMI.com
www.ClearAutoBraMI.com

5.....	Officers and Chairs
6.....	Editor's Note
7.....	Willkommen
8.....	PCA Roundup
10.....	MVR Membership News
11.....	Advertiser Index
13.....	The Mart
15.....	MVR Gathering at Rennstatt
17.....	MVR Calendar of Events
18.....	MVR Member Dinner
20.....	Crawford Auto-Aviation Museum 911 Exhibit
24.....	MVR PCA Art Tour
28.....	Online Porsche Parts Catalogs

der RÜCKSPIEGEL

Published monthly by the Maumee Valley Region, Porsche Club of America.

Advertising Rates

All rates are for 1 year:

- Business card \$85.00

- Quarter page \$165.00

- Half page \$215.00

- Full page \$320.00

- Full page inside covers \$375.00

Check or money order made out to MVR-PCA must accompany request.

Please call for shorter intervals.

Deadline for copy is the 10th of the month for the next month's issue.

On the Cover: MVR engine decklid badge photo by Bill Giezie

Newsletter layout happily provided by Sebastian Gaeta

Material from der RÜCKSPIEGEL may be reprinted (except for ads) provided proper credit is given to the author and the source. Copy is the responsibility of the advertiser.

der RÜCKSPIEGEL is the official publication of the Maumee Valley Region, Porsche Club of America. Opinions stated are those of the authors and do not necessarily represent the position of the Maumee Valley Region or Porsche Club of America. Back issues of der RÜCKSPIEGEL are available at mvr.pca.org/back-issues/.

Historical newsletters (May 1972-December 1975) are also available, thanks to our club historian, Bill Bauman.

Send pictures and articles to: derruckspiegel@gmail.com

der RÜCKSPIEGEL

MVR Officers

President

Kyle Mahan | 262-408-9196
mvrpca@hotmail.com

Vice President

Lisa Soriano | 419-843-2070
lsoriano.pca@gmail.com

Treasurer

Chris Krauser | 419-841-7984
cpjmkrauser@juno.com

Secretary

Evie Zimmerman | 419-376-0770
eviezimmerman@gmail.com

Past President

Lisa Soriano
lsoriano.pca@gmail.com

Zone 4 Representative

Dave Stetson | 614-286-5988
Zone4Rep@national.pca.org

MVR BOARD

Jeff Fort

jeffreyfort@mac.com

Jeff Vollmar

Jtvollmar@att.net

Jim Wilson

jimwilson51@gmail.com

Kim Harris

zkimberlydharris@gmail.com

Kyle Mahan

mvrpca@hotmail.com

Lee Burlingame

burlingameconstruction@gmail.com

Lisa Soriano

lsoriano.pca@gmail.com

MVR Chairs

Advertising

Dave Zimmerman | 419-376-0110
davezim911@gmail.com

Autocross

Greg Herr | 419-833-9696
greg.herr@us.o-i.com

Drivers Education

Lee Burlingame | 419-351-3001
burlingameconstruction@gmail.com

DE Chief Instructor

Todd Mierzwiak | 419-283-5593
toddm79861@aol.com

Historian

Bill Bauman | 419-475-1336
backmotor@bex.net

Insurance

Todd Mierzwiak | 419-283-5593
toddm79861@aol.com

Membership

Kyle Mahan | 262-408-9196
mvrpca@hotmail.com

Newsletter Editor

Greg Armstrong | 419-318-9014
derruckspiegel@gmail.com

Safety/Technical Advisor

Clare Valley | 419-966-3786
cvalley@roadrunner.com

Social

Krista Mahan | 608-333-6056
mvrpca@hotmail.com

Webmaster

Bob Harris | 419-861-0745
robertsharris@sbcglobal.net
mvr.pca.org

EDITOR'S NOTE

by GREG ARMSTRONG

I now know who to approach for aftermarket badges after the OEM ones get eaten if I'm ever fortunate enough to acquire a Porsche cookie car. I am also pleased to report that Bill Giezie's quest for a non-edible MVR engine decklid badge has come to a successful conclusion. Bill was kind enough to send a few pics of his new engine decklid badge to share with all of us. Thank you, Bill for the pictures and the member who supplied the badge! (I don't want to put that member on the spot, so I left their name out of it.)

The first time I had ever heard of the Crawford Auto-Aviation Museum was when I received an email from Dave Zimmerman about it. The museum has become an interim advertiser and is currently running a Porsche 911 exhibit. Details about



the museum and the exhibit are available elsewhere in this issue. Cleveland is a short trip from our area and the exhibit looks like it would be well worth the drive.

Since Valentine's Day is rapidly approaching, consider treating your significant other to a Porsche sweet or a new car. Whichever is most convenient.

Thank you for reading,

Greg Armstrong



WILLKOMMEN

by Kyle Mahan

Despite what a particular ground-dwelling rodent said I'm hoping for early spring, as I'm writing this the forecast for the week shows a high of almost 60 for Thursday. That is a welcome sign and I'm hoping that spring comes early this year so we can get back to some on-track/road events. Until then the club has had a couple of great dining events and a few more events until the spring breaks that I'm sure everyone will enjoy.

Kim Harris hosted an enjoyable dinner on January 12th at Byblos in Toledo. We attended with Kairi and Leon in tow and were welcomed to our seats with these awesome handmade Porsche Cookies (fantastic work Laura Valentine). I was lucky enough to sit next to Ruth and talk about her 944 while waiting for our food. Everyone in the family got something different so we shared as we were experiencing Byblos for the first time, and it didn't disappoint.



Unknown to me Tom Isley had a gift for me that I'm excited to preserve for the club and pass on to the next president. It was an original copy of our PCA Maumee Valley Region Charter, a little rough but a great piece of history worth saving, thanks Tom!

We are looking at an Art Museum tour event in March and our team HPDE team is hosting our 8th Annual 2023 Grattan HPDE driving school on July 28-30. You can register for the HPDE at Clubregistration.net and I hope to see you out there!

The club would like to welcome Kurt Schlagheck to MVR, and as always, we look forward to seeing everyone at an upcoming event, stay warm!

PCA Roundup

by Lisa Soriano

PCA National has worked very hard to produce content to help everyone stay connected to the club and to the cars we love so much. This is especially helpful during those winter months as we dream of warmer days and the beginning of our driving season. Here are the latest Tech Tactics Live episodes, Tech Tips, and PCA Insider Podcasts, for you to enjoy!



TechTactics LIVE:

- [Tips for attending National-level PCA events in 2023](#)
- [State of the Porsche Market: What we learned from the 2023 Scottsdale Auctions](#)

Tech Tip Articles:

- [What are the 12 Taycan variations Porsche offers for 2023?](#)
- [Porsche 904 Carrera GTS and 906 Carrera 6: Last of the street-legal race cars](#)
- [What we learned about Porsche's new 963 LMDh prototype](#)
- [Do I trust the speedometer or GPS?](#)
- [Did your low tire pressure light come on last week?](#)
- [What we learned from a retired Porsche salesman](#)
- [Five tips for Porsche fans to watch, understand the 2023 Rolex 24 at Daytona](#)

PCA Insider Podcast:

- [Episode 40: Inside peek of the 963 at Daytona, what's a Sportomatic, and bore scoring](#)
- [Episode 41: What's a 944 Turbo Cup and did PCA Sim Racing help a first-timer on the real track?](#)
- [Episode 42: PCA at sea: Behind the scenes on the Real Love Boat](#)
- [Episode 43: Porsche Resolutions for 2023](#)
- [Episode 44: Meet the new National President of the Porsche Club of America](#)
- [Episode 45: Scottsdale Auctions: Five Porsches to Watch](#)

What Would the World Have Missed if Porsche Had Discontinued the 911?

See for yourself at the Crawford-Auto Aviation Museum in Cleveland. Porsche 911: The Evolution of an Icon, presents iconic cars that would not have been if Porsche had discontinued the 911--as was planned in 1981--such as the 964 Carrera RS Lightweight; the Carrera Cup and Supercup race cars; and the Uber-Porsche, the 959.



Porsche 911: The Evolution of an Icon runs through April 2, 2023, at the Crawford Auto-Aviation Museum



Crawford Auto
Aviation Museum

10825 East Boulevard, Cleveland, OH
www.TheCrawfordMuseum.org
216.721.5722 | @crawfordmuseum



Your Neighbors,
Your Friends
Brookview
Dental

Peter Urbanik, DDS Brad Barricklow, DDS Todd Schultz, DDS Tara Bingle, DDS

brookviewdental.com • General Dentists

7135 Sylvania Ave., 1-A • Sylvania, OH 43560 • 419-885-1115

THE CAR PORT LLC

PORSCHE
SERVICE / MAINTENANCE

JOHN JENNENS
OWNER
4419 SECTION RD.
OTTAWA LAKE, MI 49267

419.356.3960
734.568.6968
YBSLO@BEX.NET

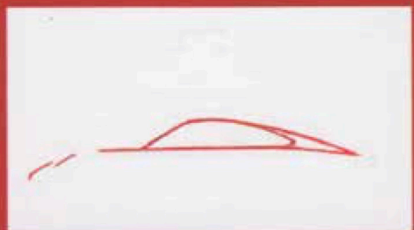

**MVR/PCA
MEMBERSHIP NEWS**

Primary Members 180
Affiliate Members 118
Total Members 298

Welcome 1 New Member!!

Kurt Schlagheck of Lambertville, MI driving a 2020 718 Cayman GT4

Moving?
Please be sure to update PCA with your new address so you don't miss an issue of der RÜCKSPIEGEL. This can be done on the PCA website at PCA.org

If you are not currently receiving Social Event email updates, please contact Kim Harris at 2kimberlydharris@gmail.com

CLUB MEMBER ANNIVERSARIES

George Reiser	25	John Burchfield	3
James & Cheryl Wilson	25	Duane Burgoyne	2
Billy Edwards	21	Lewis Greenman	2
Douglas & Lita Crocker	9	Steven VanDromme	2
Jeffrey Roberts	6	Nevin Liber	1
Brad & Sherri Longberry	4	Ernest Woeller	1

ADVERTISING INDEX

- 12.....Allied Motorworks
www.alliedmotorworks.com
- 33.....A-Team Auto Wraps
www.ateamtinting.com
- 10.....Brookview Dental
www.brookviewdental.com
- 3.....Clear Auto Bra
www.norockchips.com
- 9.....Crawford Auto-Aviation Museum
www.thecrawfordmuseum.org
- 26.....Discount Tire
www.discounttire.com
- 36.....Fort Law Firm
www.jfortlaw.com
- 33.....George Reiser, Attorney
- 34.....Fourth Dimension Financial Group
- 23.....Lexus of Toledo
www.jimwhitelexustoledo.com
- 14.....PCA Parade www.pca.org
- 16.....PCA Making a Difference
www.pca.org
- 35.....Porsche of Ann Arbor
www.porscheannarbor.com
- 25.....Porsche of Farmington Hills
www.porscheoffarmingtonhills.com
- 27.....Rennstatt
www.arbormotion.com
- 15.....Steinel's Autowerks
www.steinels.com
- 11.....The Car Port
- 32.....Tireman Service Center
www.thetireman.com
- 2.....Vin Devers Autohaus
www.vindevers.com
- 3.....Waterford Bank
www.waterfordbankna.com

ALLIED MOTORWORKS

SERVING THE WORLD'S MOTORCARS

SEEN BY APPOINTMENT ONLY, CALL TO SCHEDULE!

ALLIEDMOTORWORKS.COM
419-515-4000
INFO@ALLIEDMOTORWORKS.COM
6820 W SYLVANIA AVE
SYLVANIA, OH 43560



THE MART

For Sale: 1987 924S - 1 owner 57,000 miles, no accidents, never tracked, all original in excellent condition.

\$10,995 419-893-4698

Douglas Hileman



Silver Porsche 986 Hardtop in perfect condition

It is stored above my winterized and covered Boxster in the garage and so it's covered with a blanket to avoid dirt and scratches. As you can see in the lower picture, the glass and inside are perfect, too. The sale comes with the ceiling hoist which is designed for this top. Asking \$3,500 but open to reasonable offers.

Tom Neil tomsneil333@gmail.com or text to 248-701-9227





Don't Just Attend Porsche Parade...

...Be a Part of It!



An autocross is a closed-course driving event, and they are held in a large open area - such as a parking lot - where the objective is to safely complete the course in the shortest amount of time. New to Autocrossing? Parade is a great time to give it a try!



June 18-24, 2023
The LaQuinta Resort and Club
Palm Springs, California
www.porscheparade.org

THE GATHERING



AT RENNSTATT

A Social Event with Cars,
Coffee and Porsche Camaraderie

SATURDAY APRIL 11TH, 2023

9:00AM TO 11:00AM

669 STATE CIRCLE ANN ARBOR, MI 48108

We look forward to seeing Our MVR Friends!



2002 Midway Drive ▲ Twinsburg, OH 44087
330-425-8582 ▲ Fax: 330-425-3560

Maintenance, Restoration, and Race Preparation of Porsche Automobiles

MVR CALENDAR OF EVENTS 2023

March

3/25 - Toledo Museum of Art - 11 am tour with optional lunch at the museum's cafe

April

4/8 - The Gathering at Rennstatt (Cars & Coffee), MVR Members Invited**

4/22 - Fort's Garage Maintenance Session and Potluck (details TBD)

4/29 - Treffen (Georgia Mountains) *

May

5/6 - Driving Tour to Derby Party (Ann Arbor)

June

6/18 - 6/24 - PCA Parade (Palm Springs, CA)*

July

Ice Cream Social at Freeze Daddy (details TBD)

7/15 - Porsche in the Park (RSR) German Park, Ann Arbor**

7/28-7/30 - HPDE MVR

Aug

Summer Picnic (details TBD)

Werks Reunion (Monterey)*

Sept

Fall Treffen (St. Louis) *

9/28-10/1 - Rennsport Reunion (Laguna Seca) *

Oct

Club Fall driving tour (details TBD)

Nov

Winterize Tech Event (details TBD)

Dec

Holiday Party (details TBD)



PCA members make a difference in their community!

Porsche Club of America Regions create fantastic opportunities to give back and support many different aspects of their communities.

Every year across Porsche Club of America, members are making a difference with many amazing, heartwarming, and thoughtful acts of kindness. PCA is continually collecting stories of member's community contributions, and publishing articles for all to read in an effort to highlight what our club is doing and inspire other regions to help in their own way.

READ ALL OF THE HEART-WARMING MEMBER STORIES: www.pca.org/members-making-difference
OR SUBMIT YOUR REGION'S CONTRIBUTION: www.pca.org/contact-members-making-difference



PORSCHE CLUB OF AMERICA

MVR January 12 MEMBER DINNER EVENT AT BYBLOS

Photos provided by Jeanne Krauser



Clockwise from Above Left: Kyle, Kairi, Leon, & Krista Mahan. Marsha Palmer, Gina & Jim Konczal, Sandy & Bill Potter, Jeff Fort, Staci Fort, Cheryl & Jim Wilson, Dave Zimmerman. Jonna & Dan Dessner, Tom Isley, Bob Harris, Krista Mahan (standing), Hal Kenety, Kyle Mahan (standing), Dave & Jennifer Thomas, Jayne & Bill Giezie. Staci Fort, Cheryl & Jim Wilson, Dave Zimmerman & Marsha Palmer, Gina & Jim Konczal, Sandy & Bill Potter. Laura & Mike Valentine.



Clockwise from Above Left: Ruth Gulliford, The Mahans, Beth Stewart, Laura Valentine. Dan Dessner, Tom Isley, Kim & Bob Harris, Hal Kenety. Dave & Jennifer Thomas, Deb Isley, Jayne & Bill Giezie. Kyle & Ruth protecting the MVR Charter. Bill Giezie, Jonna & Dan Dessner, Tom Isley, Kim & Bob Harris. Jonna & Dan Dessner, Tom Isley (standing), Kim & Bob Harris. Gina & Jim Konczal.

Crawford Auto-Aviation Museum Exhibit Explores Evolution of the Porsche 911

CLEVELAND, OH—What would the automotive world have missed if the Porsche 911 had been discontinued? The question seems unfathomable today, but that was exactly what Porsche planned to do in 1981. The 911 was set to fade into history, replaced by the larger, more expensive 928 model. The Crawford Auto-Aviation Museum explores what might not



1978 930 Turbo features factory “Turbo” graphics and is a stunning example of what Porsche was willing to walk away from when it planned to discontinue the 911 in 1981.



This 1991 Carrera Cup car has significant racing history and is featured in the Crawford exhibit.

have been if Porsche had discontinued its flagship car with its newest exhibit, Porsche 911: The Evolution of an Icon opening Thursday, November 17.

With cars sourced from around Northeast Ohio with help from the Northern Ohio Region chapter of the Porsche Club of America, Porsche 911: The Evolution of an Icon shows the progress a single model made from near-death in 1981 to becoming a world-class supercar by the mid-2000s.

Porsche has had a strong presence in Northeast Ohio since 1957, when Charles A. Stoddard, a former automotive engineer at Thompson Products (where Crawford Museum namesake Frederick C. Crawford was president), opened Stoddard Imported Cars (SIC) in nearby Willoughby, Ohio.

“As far as the company was concerned, the 911 was history”

One of the first Porsche dealers in the country, SIC grew rapidly as people discovered the pleasure of driving the small, German sports cars. The introduction of the 911 in 1963 further bolstered the success of Porsche and dealers like SIC, yet that success was threatened when Porsche decided to cease production of the 911 in 1981. Fortunately for car enthusiasts around the world, then-new Porsche CEO Peter Schutz--the first American to run the company--stepped in to save the day. In 2013, Schutz wrote about his famous decision for Road & Track magazine.

“As far as the company was concerned, the 911 was history. But I overturned the board’s decision in my third week on the job. I remember the day quite well: I went down to the office of our lead engineer, Professor Helmut Bott, to discuss plans for our upcoming model. I noticed a chart hanging on his wall that depicted the ongoing development trends of our top three lines: 911, 928, and 944. With the latter options, the graph showed a steady rise in production for years to come. But for the 911, the line stopped in 1981. I grabbed a marker off Professor Bott’s desk and extended the 911 line across the page, onto the wall, and out the door. When I came back, Bott stood there, grinning.

“Do we understand each other?” I asked. And with a nod, we did.

“Do we understand each other?” I asked. And with a nod, we did”

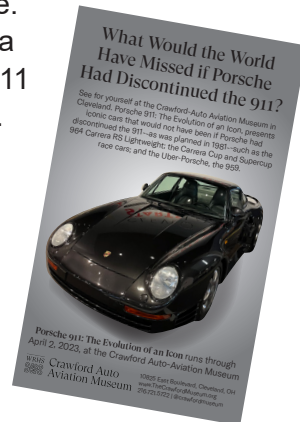

Continued on pg 22

Continued from pg 21

The Crawford Museum exhibit features fifteen gorgeous examples of Porsche’s finest sports cars, including a 959 supercar, a 964 Carrera RS Lightweight, a rare 911 M491 “Turbo-Look” Cabriolet, and two 911 race cars: a 964 Carrera Cup car with significant French racing history, and a Porsche Supercup car raced in the F1 support series. All are stellar examples of what might not have been had Porsche discontinued the 911.

Porsche 911: The Evolution of an Icon, runs through April 2, 2023, at the Crawford Auto-Aviation Museum, 10825 East Boulevard, Cleveland, OH 44106. For more information, visit www.thecrawfordmuseum.org.

About the Crawford Auto-Aviation Museum

The Crawford Auto-Aviation Museum is located at the Cleveland History Center and is part of the Western Reserve Historical Society. The Crawford—originally known as the Thompson Products Auto Album—was founded by Thompson Products (now TRW) president Frederick C. Crawford and opened on August 13, 1943, as one of the first car museums in the U.S.

In 1945, Ruth Franklin was named curator and became one of the first female museum curators in the U.S. Franklin held that position for 26 years and was the first woman named to the Board of Trustees for the Antique Automobile Club of America. Mr. Crawford’s collection became part of the Western Reserve Historical Society in 1963, and on September 11, 1965, opened its doors as the Frederick C. Crawford Auto-Aviation Museum in a new building at its current location at 10825 East Boulevard in Cleveland, Ohio.



PORSCHE AFICIANADOS KNOW BEAUTIFUL VEHICLES. THEREFORE, WE INVITE YOU TO EXPLORE LEXUS TO TRANSPORT YOU IN LUXURY EVERY DAY.



SEE JIM SCHENK at LEXUS of TOLEDO



7505 W. Central at King • Toledo, OH
419-841-3500 • JimWhiteLexusToledo.com



Jim is a 20-Year Porsche Club member and has owned 6 Porsches.

JIM SCHENK
Cell: 419-392-5252

MVR PCA Art Tour Event

11:00 am Saturday March 25, 2023

Toledo Museum of Art
2445 Monroe St
Toledo, OH 43620

Guided Tour with optional Lunch at Museum's Café

RSVP: MVRPCA@hotmail.com or Krista at 608-333-6056

The Toledo Museum of Art has ancient Egyptian artifacts to paintings by Rembrandt, Van Gogh and Picasso, the Museum's 30,000-strong art collection ranks among the finest in the U.S. and the birthplace of the Studio Glass Movement.

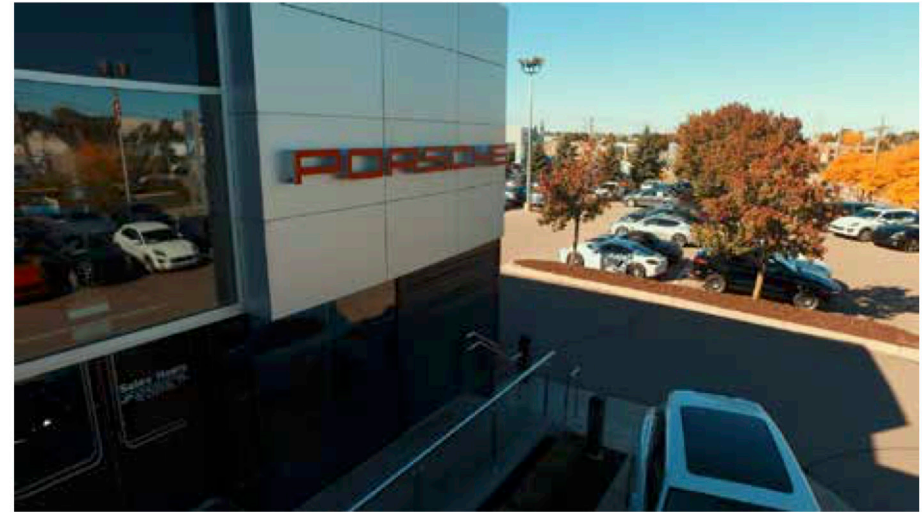
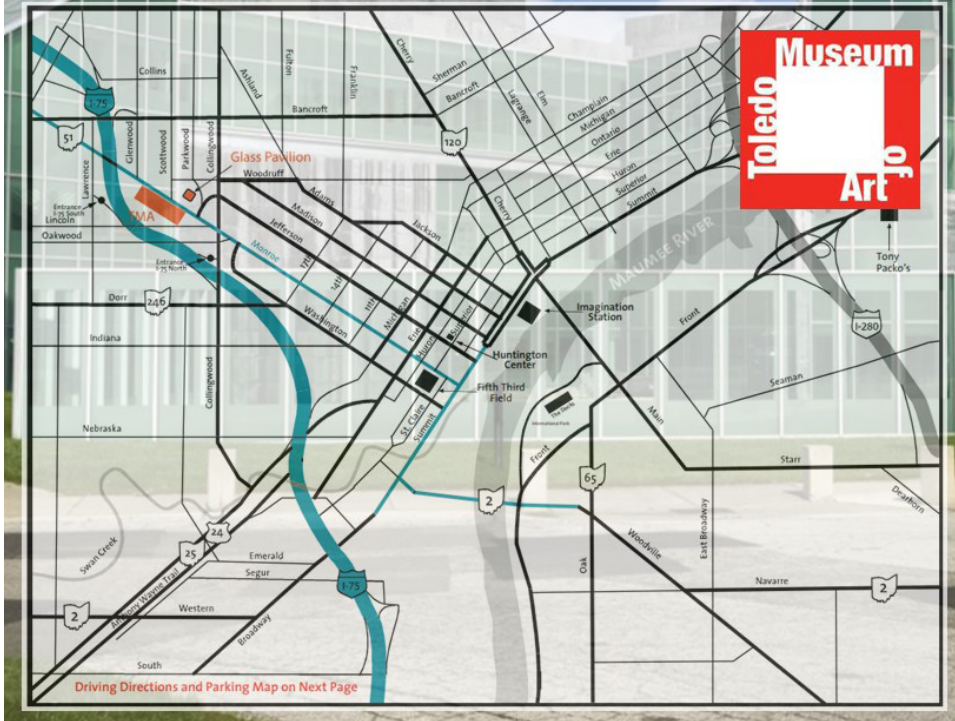

PORSCHE

Porsche of Farmington Hills



The Porsche Farmington Hills Advantage

- fully certified Porsche staff
- fast & crystal clear pricing
- relaxed atmosphere
- individualized buying experience
- gratis pickup & delivery of vehicle for service

248.471.0800

PorscheFarmingtonHills.com

37911 Grand River Ave

Farmington Hills, MI 48335

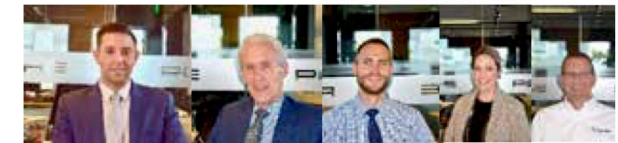

EDGE-OF-YOUR-SEAT
PERFORMANCE



Photo credit: Notbadphotography



MICHELIN BFGoodrich YOKOHAMA KUMHO TIRE 1 PIRELLI
 NITTO FALKEN Tires HANKOOK American Racing LIQUIDMETAL WHEELS
 ENKEI Drag TSW CRAY KÖNIG Vöxx

Toledo | 5030 Monroe St | 419-475-6593
 Rossford | 27135 Crossroads Pkwy | 419-872-7690

Find great deals at [tires.com](https://www.tires.com)

Over 980 stores nationwide | Mon-Fri: 8 a.m. – 6 p.m., Sat: 8 a.m. – 5 p.m.



Where America Saves on Tires™



RENNSTATT
 CERTIFIED PASSION
 FOR PORSCHE



Call
 (734) 761-1088
 for all your
 Porsche
 needs

Repair and Maintenance
 IMS Bearing Upgrade
 Timing Belts
 Suspension Upgrades
 Performance Alignments

ArborMotion
 specialized auto care

Rennstatt is the Performance Division of
 ArborMotion



669 State Circle Ann Arbor, MI 48108 (734) 761-1088
www.arbormotion.com/rennstatt

ONLINE PORSCHE PARTS CATALOGS

by Sebastian Gaeta

Porsche owners possess a DIY spirit unmatched by any other vehicle owners. Typically the biggest hurdle DIY hobbyists face when beginning a repair is pinpointing the correct parts needed for the job and a strong visual of how everything is reassembled. Contrary to popular belief there is not a YouTube video for everything on your car, especially for intricate and smaller jobs where an exploded view diagram would be of great help. In all my years of fussing with these cars exploded views have been much more helpful than any shop manual for reassembly. There is nothing less helpful when looking at a shop manual for guidance than the words "Install (part) back into place" or "Assembly is in reverse order of disassembly", but a good visual of "what goes where" is invaluable.

For those that aren't familiar, there is an on-line resource from Porsche that not only provides you with the correct part numbers but also exploded view diagrams to help you with your DIY repair. Parts Catalogs are my Bible with my vintage Porsches and can also be yours for the more modern cars. These Online PET Catalogs from Porsche, while not 100% detailed like the dealer level parts lookup, are extremely helpful in this regard.

Go Here to view them: <https://www.porsche.com/usa/accessoriesandservices/classic/genuineparts/originalpartscatalogue/>

Scroll down until you see this drop down menu

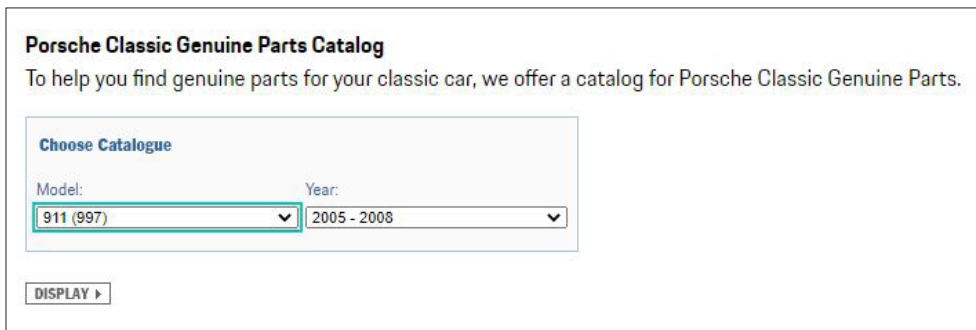

Choose your vehicle and click "DISPLAY", it will download the entire catalog for that vehicle in PDF form. Upon opening the PDF you will be able to search by part name or number and you will be amazed at the information available to you. The following are some examples.

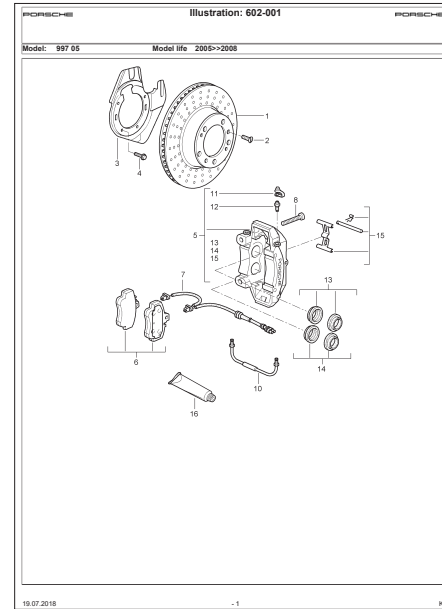

Part Number	Description	Remark	Qty	Model
1	996 351 405 01	Brake disc	left front	1
13	996 351 409 02	Brake disc	left front	1
13	996 351 031 04	Brake disc	left front	1
13	997 351 031 00	Brake disc	left front	1
13	997 351 031 01	Brake disc	left front	1
13	996 351 406 01	Brake disc	right front	1
13	996 351 410 02	Brake disc	right front	1
13	996 351 032 04	Brake disc	right front	1
13	997 351 032 00	Brake disc	right front	1
13	997 351 032 01	Brake disc	right front	1
2	900 249 047 09	counterarm bolt		4
2	900 249 047 01	counterarm bolt		4
13	997 351 805 00	Cover plate	left	1
13	997 351 805 04	Cover plate	left	1
13	997 351 805 05	Cover plate	left	1
13	997 351 806 00	Cover plate	right	1
13	997 351 806 04	Cover plate	right	1
13	997 351 806 05	Cover plate	right	1
4	998 217 116 09	Hexagon bolt		4
5	997 351 421 00	caliper without brake pads	left	1
5	996 351 429 10	caliper without brake pads	left	1
5	996 351 431 10	caliper without brake pads	left	1
5	996 351 431 31	caliper without brake pads	right	1
5	997 351 422 00	caliper without brake pads	right	1
5	996 351 430 10	caliper without brake pads	right	1

Above left is an example of the exploded view diagrams in the parts catalogs, in this case for 997 brakes. Above right is an example of the pages after the diagrams that provide Porsche part numbers that correspond to the exploded view. Below are more examples of the exploded views in the parts catalogs. Imagine trying to reassemble the exhaust or the center console on your 718 without the right parts or seeing the order in which everything goes back together.

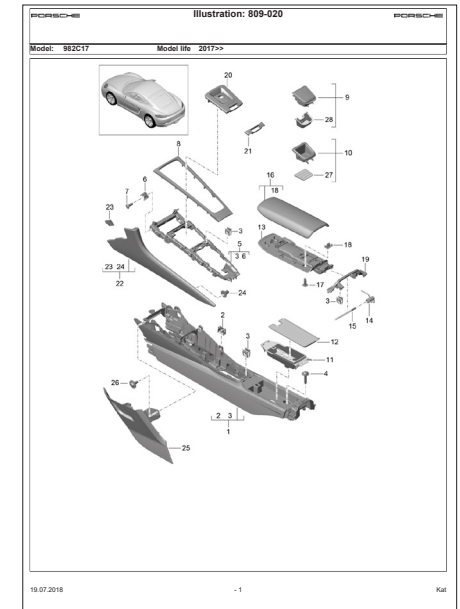
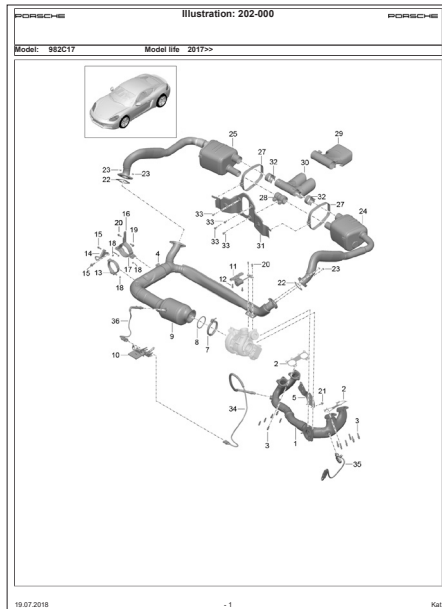

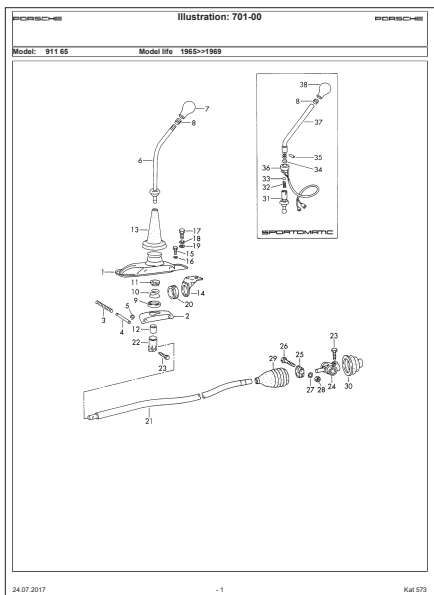
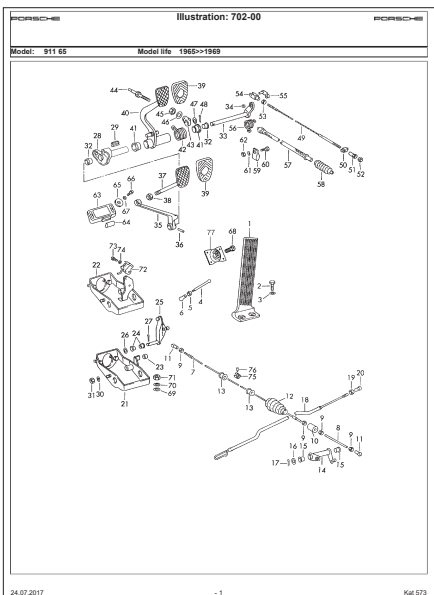

Above are exploded views of the early 911 pedal cluster and shift lever components, something a fairly skilled hobbyist can rebuild. Imagine how helpful these diagrams are in finding all the needed parts and seeing the exact the order of reassembly. Below right is the exploded view of a 914 bumper and all associated hardware; the part numbers page also provides the correct hardware sizes. Below left is a 356 B/C door handle. I have taken many of these apart but always refer to this page when doing reassembly.

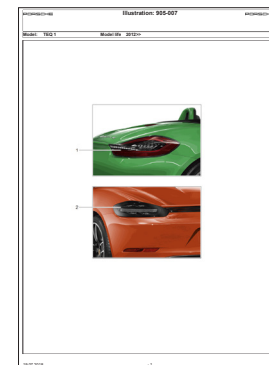
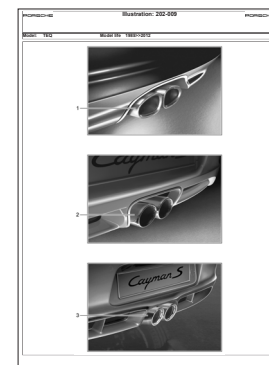
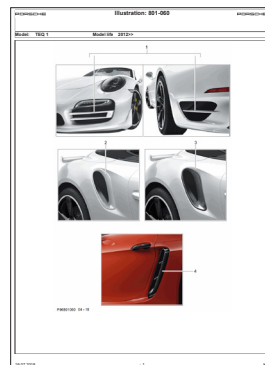
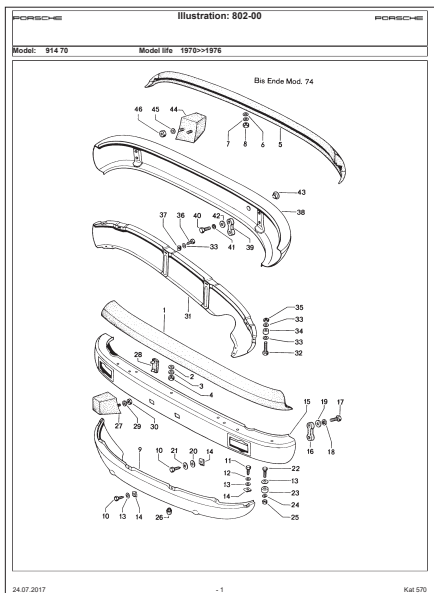
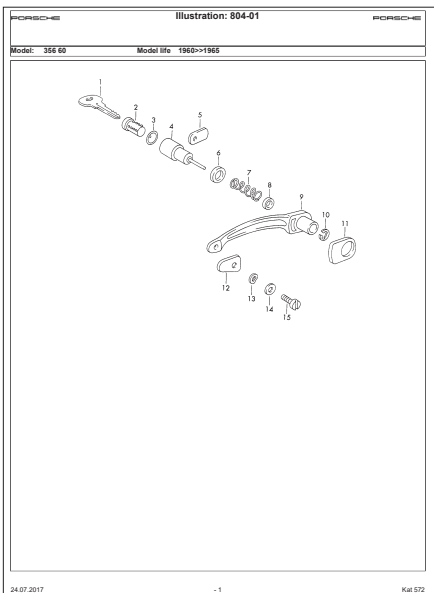

Even if you are not a do it yourselfer these catalogs can be a great source of information. Here are some examples of things you can look up, like different wheels or even available Tequipment for you car. And if you are curious about the Carrera GT, 991 GT3 and the 918 Spyder there are catalogs available for them too. Happy Reading!

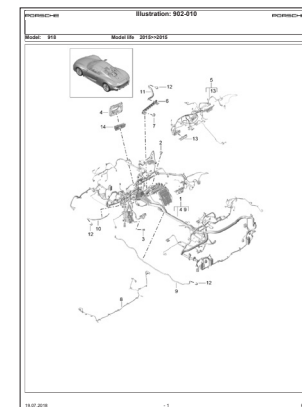
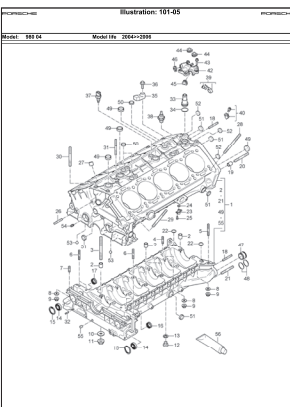
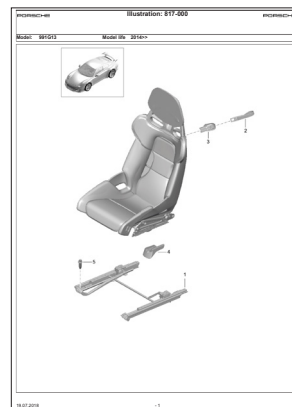
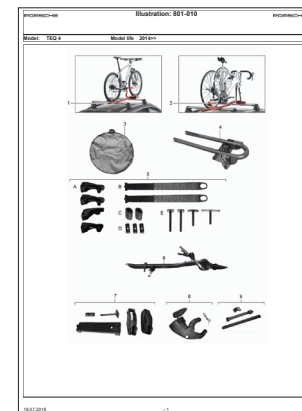
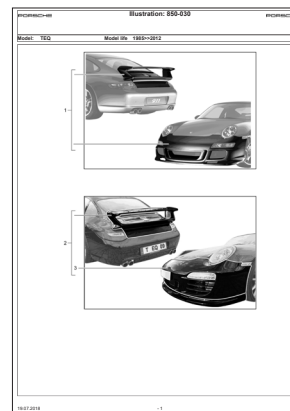

YOUR PERFORMANCE ALIGNMENT SPECIALISTS

ADJUSTMENTS MADE TO YOUR SPECIFICATIONS*



*EXTRA CHARGES MAY APPLY. SEE TIREMAN ASSOCIATE FOR DETAILS.

TIREMAN

DR INSTANT SAVINGS

Save **\$30** ON ANY 4 TIRES

ANY BRAND • ANY SIZE
NO OTHER DISCOUNTS APPLY • INSTALLATION REQUIRED
EXPIRES 10/31/2020

419-893-7242

532 ILLINOIS AVE • M-F 7:30-7 • SAT 7:30-4 • SUN 10-4

THE LOWEST OUT THE DOOR TIRE STORE

TIREMAN
AUTO SERVICE CENTERS



THETIREMAN.COM
SHOP. SCHEDULE. SAVE.



GEORGE K. REISER ATTORNEY AT LAW

5749 PARK CENTER COURT TEL: (419) 242-9501
TOLEDO, OHIO 43615 CELL: (419) 290-0432

EMAIL: greiser@greiserlaw.com

**PCA MEMBER, PORSCHE OWNER, and ATTORNEY
at LAW for over 25 YEARS.**

HERE TO ASSIST, HAPPY TO HELP, PLEASE CALL!



SunTek *Ceramic Pro*

OFFICIAL PAINT PROTECTION FILM

Professional Window Tinting
Automotive-Residential-Commercial

- Paint Wraps & Vinyl Installations
- Interior & Exterior Detailing Services
- Remote Starters, Alarms, GPS Tracking & DVDs
- Paint Protection Films
- Custom Interior & Exterior HID & LED Lighting
- Backup Camera, Dash Cams, Parking Aid & Sensors
- Cars, Trucks, SUV's, ATVs, Planes, Motorcycles, Motorhomes, Boats & Trailers

A-TEAM
Auto Wraps
& Window Tinting

Northwest Ohio's Leader in Vehicle Protection & Customization

Raron Siek
Owner / MASTER INSTALLER

5525 Schultz Dr
Sylvania, OH. 43560
419-534-0350
ateamwindowtinting.com
ateamautowraps@gmail.com

CERAMIC PRO



THE DESIGNERS AT PORSCHE DIDN'T JUST HOPE THEY MADE A GREAT CAR. THEY PLANNED IT. Have you designed your retirement plan with even half as much care as was put into your car?

By starting with a written plan, I've helped hundreds of families build and maintain their retirement plans, allowing them to retire with confidence and with more income than they often thought possible. Is it time for you to build a Financial Blueprint for your retirement?

Wondering if you're on the right road with your retirement and investment planning? MVR Members: request a **free** copy of my book: *OFF THE RECORD – Secrets To Building A Successful Retirement And A Lasting Legacy*. Simply email Adam@FourthDimensionFinancial.com or call (419) 931-0704 and we'll mail it to you, along with information about how to design a Financial Blueprint for yourself.

You enjoy the performance of exquisite automobiles; now enjoy the confidence of a Financial Blueprint for your retirement.

ADAM CUFR, RICP®: the founder of Fourth Dimension Financial Group, LLC in Perrysburg, a retirement planner and investment advisor, financial author, and proud owner of a 1972 Porsche 911.

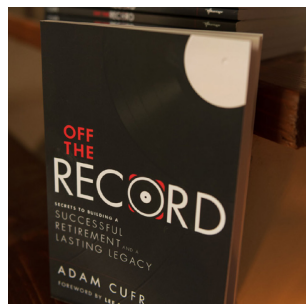

Classic in the making.

At Porsche Ann Arbor, your air-cooled Porsche is in good hands.

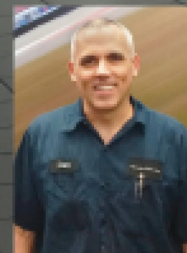

Meet Danny Young
Porsche Gold Meister Technician

Porsche Club member and veteran technician Danny Young has worked at Porsche Ann Arbor for more than 30 years, and enjoys weekend autocross events in his Boxster S as well as coaching his son in racing. Danny's love of air-cooled engines began when he learned to maintain his first car, an air-cooled '76 Volkswagen Beetle. Since then, he's continually trained with the best to become a Gold Meister Technician. Let Danny handle your classic or air-cooled Porsche service for peace of mind that your car is in the hands of the best.

Porsche of Ann Arbor
2675 S. State St.
PorscheAnnArbor.com



Fort Law Firm

413 N. Main St.,
Findlay, OH 45840

Porsche owner and MVR member.

CONGRATULATIONS MVR

**50 GREAT YEARS WITH
PORSCHE**

Large firm experience, small town service.

Jeffrey E. Fort, Attorney at Law 419-356-3984

Email: jfort@jfortlaw.com